

Simple & Clean Stainless
Steel Construction

Multiple Curves,
Inclines & Declines

Industry Best
Product Transfers

High Speed Performance
– Up to 250 FPM



AquaGard[®] 7100 SERIES CONVEYORS

The Next Generation in Stainless
Flexible Chain Conveyors!

DORNER[®] 

AquaGard® 7100 SERIES

7100 Series Conveyors are Best for:

- Packaging
- Bottling
- Dry Food Processing
- Secondary Packaging
- Inclines, Declines & Curves
- Part Handling
- Transfers
- Long Lengths
- Elevation Changes
- Accumulation
- Buffering

Sizes & Measurements

Chain Width	114 mm (4.5 in)	190.5 mm (7.5 in)	254 mm (10 in)	305 mm (12 in)
Frame Width	127 mm (5 in)	205 mm (8 in)	267 mm (10.5 in)	317.5 mm (12.5 in)
Max Part Width	241 mm (9.5 in)	317.5 mm (12.5 in)	381 mm (15 in)	432 mm (17 in)
Max Length	30.5 m (100 ft)			

Loads & Speeds

- Loads up to 317.5 kg (700 lbs)
- Speeds up to 101 m/min (222 ft/min)

Flexible Chain Types

- Standard
 - Low Friction
 - Friction Insert
 - Roller Top
- Specialty
 - Metal Chain
 - Grip Top Chain
 - Cleated Chain



Low Friction

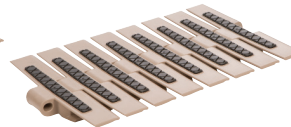

Friction Insert

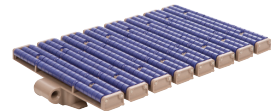

Roller Top

Guiding Options



Fully Adjustable

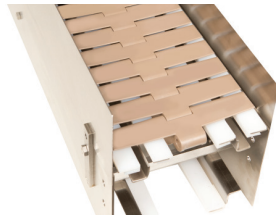

Stainless High Sides

Adjustable Outboard Guides Also Available

Stands

- Fixed Foot Support Stands
- Stainless Steel, 2B Finish
- Durable Welded 7 ga Construction
- Incline Mount Version for Angled Applications
- Other Options Also Available



Transfers

- Industry-Best Transfers
- Multiple Mounting Configurations

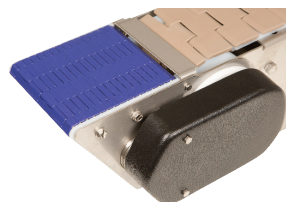

Powered Transfer



Roller Transfer



Side to Side Transfer

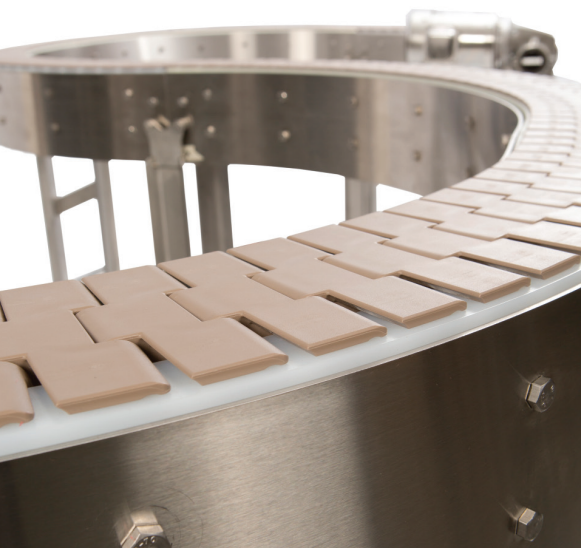

Clean & Innovative Design

- Smooth frame design for ease of cleaning
- Capable of multiple curves as well as inclines and declines on a single conveyor
- Plain bend corners with 610 mm (24 in) on centerline radius use FDA approved oil impregnated wear strips
- Inclines and declines available up to 30 degrees
 - Incline angles are integrated into the intermediate modules

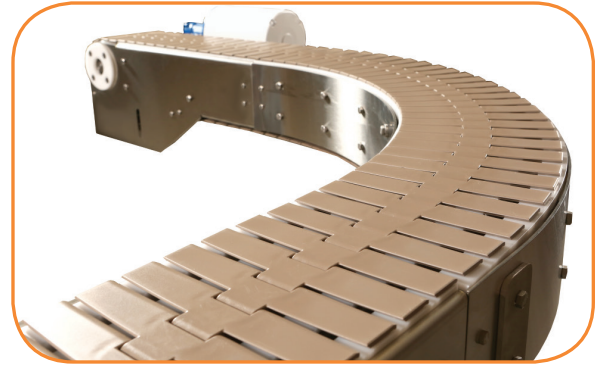

Innovative Transfer Options

- Powered Transfers
 - Provides smooth in line transfer of small parts
 - Slave driven off of drive or idler module
 - Transfers parts as small as 76 mm (3 in) in diameter
- Standard Tails Side to Side Transfer
 - Side by side drive / idler tail
 - 25 mm (1 in) from chain edge to edge
- Side Transfer Modules
 - Intermediate module that brings chain past the frame edge
 - 3 mm (1/8 in) from chain edge to edge



Compact Drive Module & Idler Tail

- Idler Tail
 - 305 mm (12 in) long
 - Bearings are located inboard
 - Flush design for side transfers
 - Sprocket comes standard for added shaft or powered transfer
- Drive Tail
 - 610 mm (24 in) long with a 127 mm (5 in) diameter sprocket
 - Catenary belt take-up with sight gauge
 - Motor can be mounted to the side or underneath

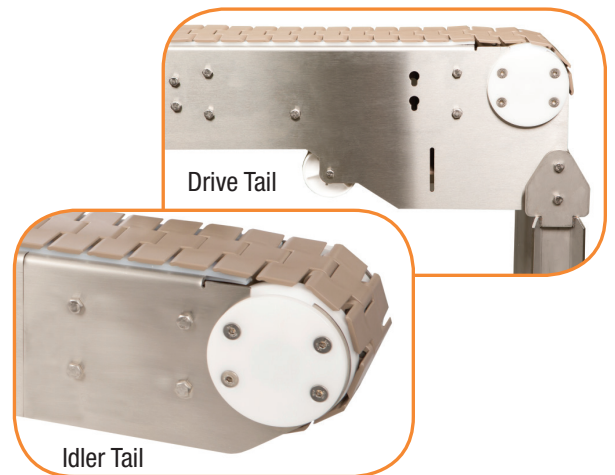

The Benefits of a Dorner AquaGard 7100 Series Conveyor

Industry Ready

- 300 Series Stainless Steel frame
- All materials are FDA approved plastics and Stainless Steel

Quality Construction

- FDA approved oil impregnated wear strips on curves
- Bolt together construction for modularity and future add-ons

Time Saving

- Dorner's online configurator engineers simple or complex conveyors to meet your needs in minutes
- The industry leading tool delivers a complete 3D CAD assembly model for instant validation of fit
- 7100 Series conveyors are shipped in sub-assemblies for fast and simple installation

Industrial & Automation Conveyors

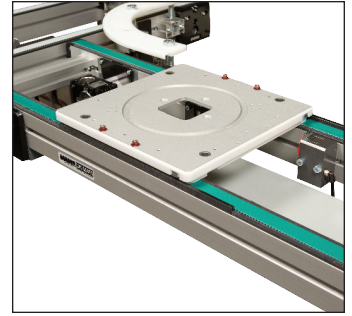
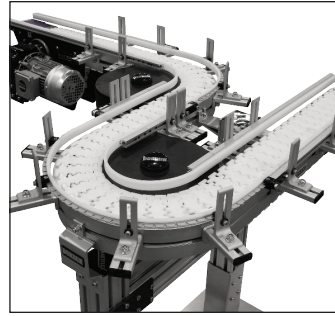
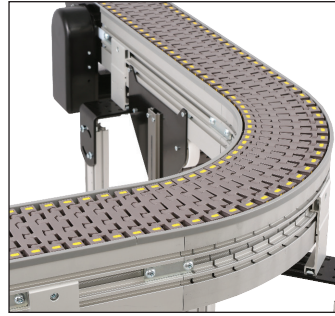

Sanitary Conveyors

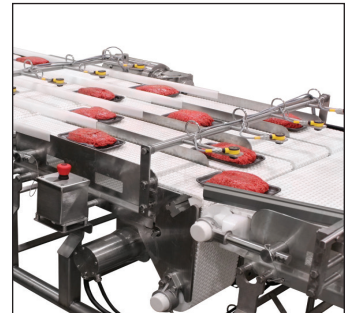
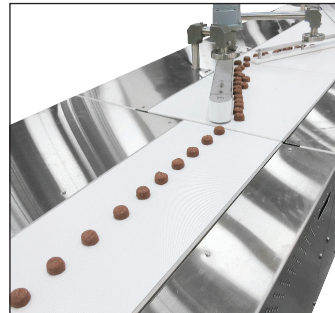
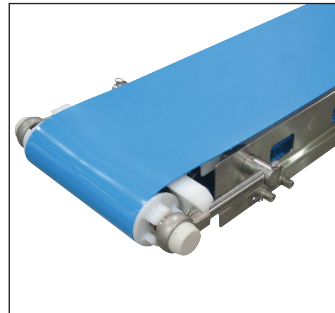
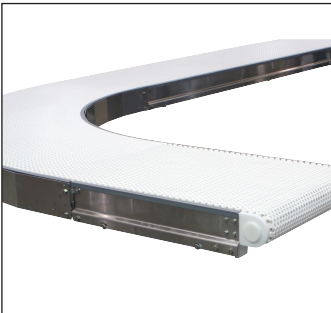

Engineered Solutions



Parts

Service

Online Configurator

Warranty

Transforming Conveyor Automation

Dorner – North & South America

Dorner – U.S.A.

Headquarters
975 Cottonwood Ave
Hartland, WI 53029, USA
(800) 397-8664
(262) 367-7600
info@dorner.com

Dorner – Canada

100-5515 North Service Road
Burlington, Ontario L7L 6G6
Canada
(289) 208-7306
info@dorner.com

Dorner – Latin America

Carretera a Nogales #5297,
Nave 11. Parque Industrial Nogales
Zapopan, Jalisco C.P. 45222
Mexico
+52.33.30037400
info.latinamerica@dorner.com



Dorner – Europe

Dorner – Germany

Karl-Heinz-Beckurts-Straße 7
52428 Jülich, Germany
+49 (0) 2461/93767-0
info.europe@dorner.com

Dorner – France

8-10 Rue de Nieuport
78140 Vélizy-Villacoublay,
France
+33 (0)1 84 73 24 27
info.france@dorner.com

Dorner – Asia

128 Jalan Permatang Damar Laut, Bayan Lepas 11960
Penang, Malaysia
+604-626-2948 | info.asia@dorner.com



www.dornerconveyors.com